

FPGA IMPLEMENTATION OF RC4 STREAM CIPHER CRYPTOGRAPHY ALGORITHM

S. Kishore Reddy*

A. Ravi Shankar**

ABSTRACT

In this paper, an efficient hardware implementation of the RC4 stream-cipher is proposed. In contrary to previous designs, which support only fixed length key, the proposed implementation integrates in the same hardware module an 8-bit up to 128-bit key length capability. Independently of the key length, the proposed VLSI implementation achieves a data throughput up to 22 MBytes/sec in a maximum frequency of 64 MHz. The whole design was captured by using VHDL language and a FPGA device was used for the hardware implementation of the architecture. A detailed analysis, in terms of performance, and covered area is shown.

*Associate Professor, Department of ECE, SITS, Khammam.

**M.Tech., JNTU-HYD University, Andhra Pradesh, India.

I. INTRODUCTION

The main feature of cryptography is to work out with problems, which are associated with secrecy, authentication and integrity. Cryptography also, is related with the meaning of protocol. A protocol is sequences of actions, which are concern two or more sides, designed to fulfill a goal. Thus, a cryptographic protocol is a protocol that uses cryptography. This protocol uses a cryptographic algorithm and its intention is to prevent attempts of thefts and invasions. Nowadays cryptography has been developed in a science strongly validated using terms of Theory of Statistics and Theory of Numbers [1, 2].

In order to handle all the cryptographic problems many kinds of cryptographic algorithms have been invented. The complexity of these problems made several categories of cryptographic algorithms. A much known is the RC4 stream cipher.

RC4 is a variable-key-size stream cipher developed in 1987 by Ron Rivest for RSA Data Security, Inc. While some key weakness have been introduced [3], the RC4 is used for encryption in the wired equivalent privacy (WEP) [4] protocol (part of the IEEE 802.11 wireless LAN security standard), IEEE 802.11 i [5], Lotus Notes, Apple computer's AOC and Oracle secure SQL. The IEEE 802.11 i uses the Temporal Key Integrity Protocol (TKIP) and the Advanced Encryption Standard (AES) [6]. TKIP uses the RC4 stream cipher as the encryption and decryption algorithm and all involved parties must share the same secret key. The RC4 stream cipher works in two phases, key setup and ciphering. During an n-bit key setup (n is the key length), the encryption key is used to generate an encrypting variable using two arrays, state and key, and n number of mixing operations [1].

In this paper a new hardware implementation of the RC4 stream cipher. is presented. The implementation is parameterized in order to support variable key lengths. The key length could be 8-bit up to 128-bit opposed to the previous designs [7, 8, 9] that supports only fixed key lengths. The proposed implementation needs three clock cycles per byte generation, in the key setup phase, and three clock cycles per byte generation, in the ciphering phase. $768 + 3*n$ clock cycles needs at total, (n is the number of bytes of the plaintext/cipher text), to complete the whole operation. Comparing with the implementations in [7, 8] the proposed one is much faster. The implementation in [9] needs the same time ($768 + 3*n$ clock cycles) with the proposed one but works with fixed key 40-bit in length. Finally, in [10] a RC4 stream cipher software implementation is presented. In this implementation assembly language was used. On a 150 MHz Pentium achieves a throughput of 20 Mbytes/sec. The

main disadvantage of this implementation is that encrypts/decrypts one byte at every seven-clock cycles resulting a rapid increment of the algorithmic latency.

The paper is organized as follows. Section 11 describes the RC4 stream cipher. In section III the proposed architecture is presented and analyzed in details. The VLSI implementation results are shown and discussed in section IV and finally conclusions are given in section V

II. RC4 STREAM CIPHER

RC4 uses a variable length key from 1 to 256 bytes to initialize a 256-byte array. The array is used for subsequent generation of pseudo-random bytes and then generates a pseudorandom stream, which is XORed with the plaintext/cipher text to give the cipher text/plaintext.

It works in Output Feedback (OFB) mode [II] of operation. There are two 256-byte arrays, S-Box and K-Box. The S-array is filled linearly, such as $S_0=0, S_1=1, S_2=2, \dots, S_{255}=255$. The K-array consists of the key, repeating as necessary times, in order to fill the array. The RC4 stream cipher works in two phases. The key setup phase and the pseudorandom key stream generator phase. Both phases must be performed for every new key.

Figure 1 shows the block diagram of the RC4 two phases.

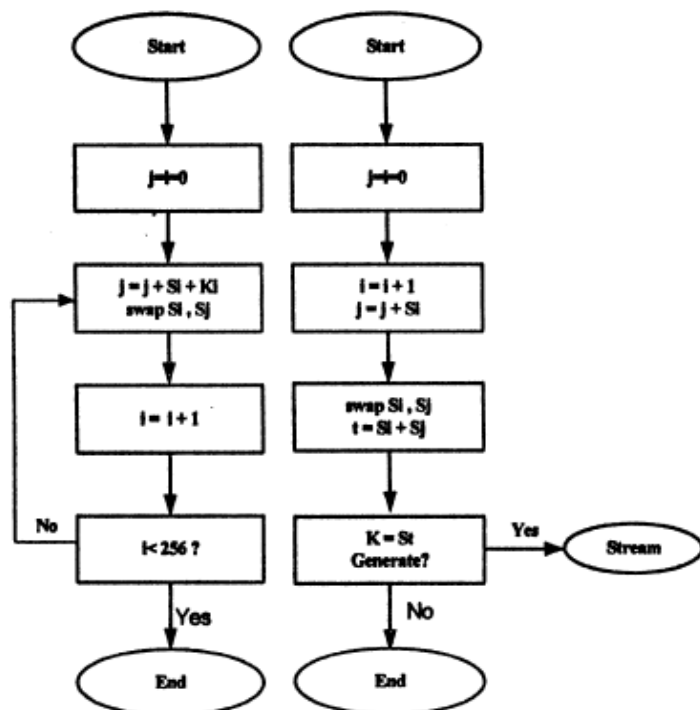

FIGURE 1
BLOCK DIAGRAM OF RC4 PHASES.

RC4 uses two counters, i and j , which are initialized to zero. In the key setup phase the S-box is being modified according to pseudo-code:

Key setup phase:

$$for\ i = 0\ to\ 255$$

$$j = (j + S_i + K_i) \bmod 256$$

swap S_i and S_j

Once the key setup phase is completed the second phase encrypts or decrypts a message. The pseudorandom number generator (PRGN) phase is described by the following pseudo code:

Key stream generation phase:

$$i = (i + 1) \bmod 256$$

$$j = (j + S) \bmod 256$$

swap S_i and S_j

$$t = (S_i + S_j) \bmod 256$$

$$K = S_t$$

The key stream K is XORed with the plaintext/cipher text to produce cipher text/plaintext.

III. PROPOSED ARCHITECTURE

Figure 2 shows the block diagram of the proposed architecture. It consists of a control and a storage unit. The storage unit is responsible for the key setup and key stream generation.

The implementation of the storage unit is shown in Fig. 3. The storage unit contains memory elements for the S Box and K-Box, along with 8-bit registers, adders and one multiplexer.

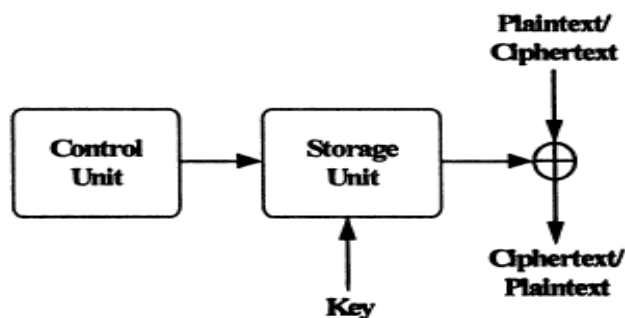

FIGURE 2
BLOCK DIAGRAM OF RC4 STREAM CIPHER.

The block diagram of the S-box RAM is shown Fig. 4. It consists of three 256 bytes RAM blocks. Each RAM block has four inputs and one output. The two inputs are the read and write signals while the other two are the address and data signals. Also, all the three RAM boxes have the same signals of clock and reset. The operation of RAM blocks is quite simple. If the reset signal occurs the blocks are initialized linearly. For each block, if the write signal occurs new data are stored in the address position, or if the read signal occurs the data in the address position are available on the output of the block.

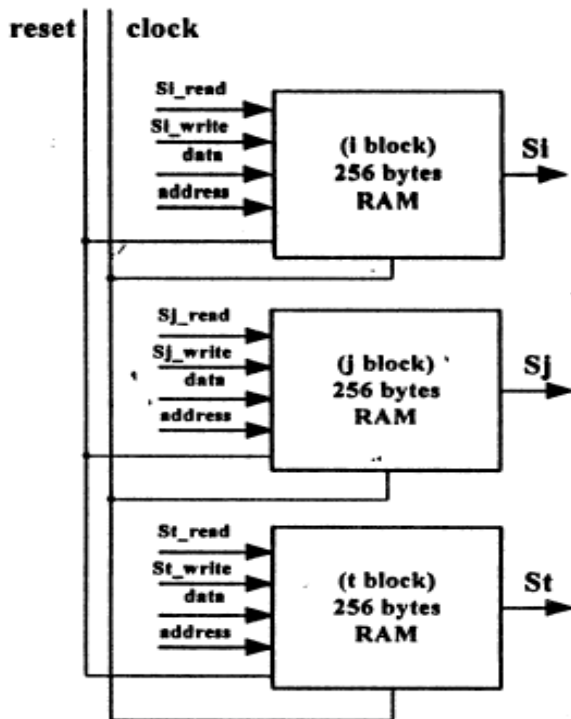

FIGURE 4
THE S-BOX RAM

The two first blocks i , j (Fig. 4) are used for the swapping of the values of the third block t . The final values that are used for the algorithm are produced by the t block.

First, the key setup phase is divided in two steps. In the first step the S-box is filled. The S-Box is initialized linearly, such as $S_0=0$, $S_1=1$, $S_2=2 \dots S_{255}=255$ when the reset state occurs. In the second step of the key setup, the S-Box is randomized. For the S-box, 3×256 -bytes RAM memory is used as it's shown in Fig. 4. The S_i and S_j registers are used for the necessary by the algorithm swappings. The j and t registers are used in order to temporary store all the intermediate variables that are produced.

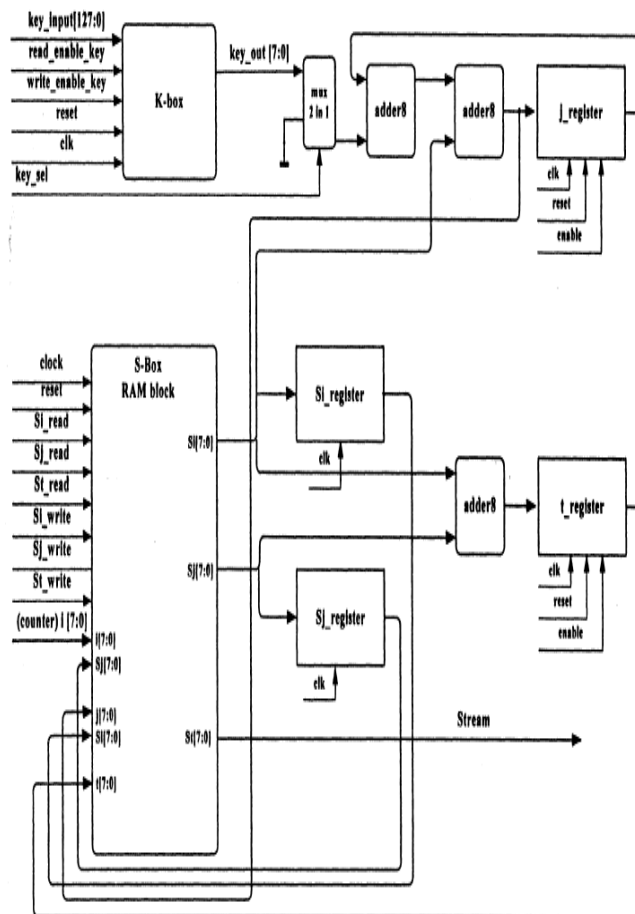

FIGURE 3
STORAGE UNIT IMPLEMENTATION

At the first clock cycle the value of counter i (see Fig. 3) is used as address in the first RAM block. The value of S_i is used for the computation of the new value of f_j as it is shown in Fig. 3. It is stored in the S_i -register. The two adders are used for the computation of the new value of f_j . They accept as input the values of K_i and S_i . At the second clock cycle the new produced value j is used as address for the second RAM block. The stored value in this address is temporarily stored in the S_j -register. At the third cycle the contents of the S_i -register and S_j -register are written at the j and i addresses correspondingly. With this procedure, the swapping is achieved.

This step needs three clock cycles per iteration. So, the total cycles that are needed in the key setup phase are $256 * 3 = 768$.

The second phase is quite similar with the first phase and so; the same hardware is being used. The difference in this phase is that the values of the K-Box are not used. After, the first phase completion, the mux selects the zero value input. Also, the $_register$ is initialized to

zero -so as to be ready for the second phase. After the two mentioned phases, the procedure of stream generation can begin.

The operations at the first three steps are similar to those of the key setup phase except that the S-Box is already initialized. At the first step the value of i is used as address in the first RAM block, the value of S_i is stored in the S_i register. Also the new value of j is computed. At the second step the new value of j is used as address of the second RAM block and the value of S_j is stored in the S_j register. In this step the values of S_i and S_j are being added and the result of the addition is stored in the S_t register. At the third step the contents of the S_i register and S_j register are written at the j and i addresses correspondingly and the value of the t register is being used as address for the third RAM block. So, the value of S_t is also produced in the third step. This value of S_t is the stream-generated byte.

After the completion of this phase, each byte in the key stream can be generated and used for encryption/decryption. The encryption/decryption is achieved by the bitwise XORing of the key stream with the plaintext/cipher text.

The total duration time of this phase is $3*n$ (n is the number of bytes of the plaintext or cipher text) and the total duration time of the whole procedure of the two phases is $768 + 3*n$.

The operation of the storage unit is synchronized by the control unit. The control unit is responsible for the generation of the clock and control signals.

IV. VLSI IMPLEMENTATION RESULTS

The proposed architecture was captured by using VHDL. All the system components were described with structural architecture. The system tested using confirmed test vectors [12] in order to examine its correctness. The whole design was synthesized, placed and routed by using XILINX FPGA device [13]. Synthesis results for the proposed implementation are shown in Table I.

TABLE I
RC4 FPGA IMPLEMENTATION RESULTS

FPGA DEVICE	Xilinx 2V250fg256	
Area Allocation	Used/ Available	Utilization
I/Os	139/328	80.81 %
Function Gen.	256 /3072	8.33 %
CLB Slices	138/1536	9 %
Dffs or Latches	279/3588	7.78 %
RAM Blocks	768 bytes	
F (MHz)	64	
Throughput (After Setup)	22 (MB/s)	

The VIRTEX XILINX 2V250FG256 device has 18K bit select RAM blocks. Each block is synchronous and can be easily configured in 256-byte RAM block. The proposed implementation uses a 3*256-byte RAM blocks.

Comparison between the proposed RC4 implementation and other previous reported Implementations [7, 10] are presented in Table II..

TABLE II
RC4 IMPLEMENTATIONS COMPARISON

RC4 ARCHITECTURE	[7]	[10] Software	Proposed
CLB Slices	255	-	138
Frequency (MHz)	17.8	150	64
Throughput (MB/s)	2.22	20	22

The implementation results are referred for the same FPGA module. The rest of the previous publications did not give information about the performance.

For the full execution of the algorithm the proposed implementation needs $768 + 3*n$ clock cycles (n is the number of bytes of the plaintext/cipher text). The implementation in [8] needs $1280 + 4*n$ clock cycles. 256 cycles in order to fill linearly the S-Box, and 1024 cycles for the key setup phase.

The implementation in [9] needs the same time ($768 + 3*n$ clock cycles) with the proposed one but works only with fixed key 40-bit in length. Finally, the software implementation in [10] encrypts/decrypts one byte at every seven clock cycles and of course increases the total latency of the algorithm execution.

V. CONCLUSIONS

A VLSI implementation of the RC4 stream cipher is presented in this paper. The proposed design provides high data throughput using 8-bit word and variable key length, from 8-bit to 128-bit, contrary to previous designs, which support only fixed length key. It provides flexibility as it can be used in many applications with any key length from 8-bit to 128-bit. The proposed system achieves a data throughput up to 22 MBytes/sec in a clock frequency of 64 MHz. The measurement results and comparisons with previous implementations prove that the proposed one is a flexible solution for any cryptographic system.

VI. REFERENCES

- [1] B. Schneier, "Applied Cryptography - Protocols, Algorithms and Source Code in C", Second Edition, John Wiley and Sons, New York, 1996.

- [2] A. Menezes, P. van Oorschot, and S. Vanstone, "Handbook of Applied Cryptography", CRC Press, 1996.
- [3] S. Fluhrer, I. Mantin, and A. Shamir. "Weaknesses in the key scheduling algorithm of RC4 ". In Proc. 8th Workshop on Selected Areas in Cryptography, LNCS 2259. Springer Verlag, 2001.
- [4] Overview of IEEE 802.11b Security, Intel Technology Journal Q2, 2000.
- [5] 802.11b Security Overview Part I, Jesse Walker, Intel Corporation, <http://www.ocate.edu/wirelcss4.ppt>
- [6] "Advanced encryption standard", <http://csrc.nist.gov>
- [7] P. Hamalainen, M. Hannikainen, T. Hamalainen and J. Snarinen, "Hardware Implementation of the Improved WEP and RC4 Encryption Algorithms for Wireless Terminals", The European Signal Processing Conference (EUSIPCO'2000), September 5-8, 2000, Tampere, Finland, pp. 2289-2292.
- [8] P. D. Kundarewicz, S. J.E. Wilton, A. J. Hu, "A CPLD- Based RC4 Cracking System", The 1999 Canadian Conference on Electrical and Computer Engineering, May 1999.
- [9] K.H Tsoi, K.H Lee and P.H.W Leong, "A Massively Parallel RC4 Key Search Engine", Proc. of the 10th Annual IEEE Symposium on Field-Programmable Custom Computing Machines (FCCM'02), September 22 - 24, 2002 Napa, California, pp. 13-21.
- [10] B. Schneier, D. Whiting, "Fast Software Encryption: Designing Encryption Algorithms for Optimal Software Speed on the Intel Pentium Processor", Fast Software Encryption workshop (FSE97), LNCS, Vol. 1267, pp. 242-259, Springer-Verlag, Haifa, Israel, January 20-22, 1997.
- [11] "Recommendation for Block Cipher Modes of Operation. Methods and Techniques". National Institute of Standards and Technology, Technology Administration, U.S. Department of Commerce. <http://csrc.nist.gov/publications/nistpubs/800-8a/sp800-38a.pdf>
- [12] Confirmed Test Vector for RC4, <http://www.qrst.de/html/dsds/rc4.htm>
- [13] Xilinx Inc., San Jose, Calif., "Virtex, 2.5 V Field Programmable Gate Arrays," 2003, www.xilinx.com