

**MATHEMATICAL MODELLING SINGLE WINDOW DIGITAL UNIVERSITY FRAMEWORK:
COMPUTATION OF SUSTAINABILITY**

Shipra, Department of Mathematics, Pt. NRS Govt. College, Rohtak.

Emailid; shipra.kadyan2502@gmail.com

ABSTRACT

In accordance with the Mission "Digital India Program," the Government of India introduced the "Digital University Framework" (DUF) to make it easier for students, parents, teachers, and university administrators to manage their infrastructure in a transparent, effective, and affordable way. In terms of cyber security audits, data synchronization, live data sharing with other applications, data usage, offsite backups, data mirroring, and not maintaining "Disaster Recovery Sites," among other things, a number of these developed and implemented applications do not fully comply with the standard web policy, putting data at risk. The idea of a single window system has been rendered useless due to a lack of a "centralized & standardized" approach to application development and implementation. Additionally, the accrued benefit has been taken away from our "admission aspiring students," who are now hopping from University to University in search of admission. How successful would be the Planning, Design, Development, Implementation, e-Services of single window centralized & integrated system of "Digital University Framework" in light of this study of all Universities? However, given the various technological platforms, planning, implementation, management, support, e-services, and functional requirements, it is challenging to guarantee the success of the produced system. Sustainability must be an integral part of any project work under the Plan and Development. Planners and developers must ensure that under specified circumstances, the product being planned & built can be retained for a long time. A construction work or project's sustainability factors may be the content, machine, maintenance, technology, audiences, funds, climate, performance, impacts, benefits, adoptability, usability and user-friendliness selected, and accessibility by different strata of society at large. It can be called an Unobservable Variable or a Latent Variable, meaning that it cannot be explicitly calculated. It always relies on the output of some other predictor or manifest variables or their outcome. Sustainability is therefore often referred to as a dependent latent variable, measured and directly proportional to the indicator variable's output. This research revolves around the estimation and sustainability prediction of various e-governance initiatives. Chan and Lee (2008) discussed a few more basics of sustainability when assessing government projects, i.e. the ability to corroborate or substantiate an argument and the ability to continue or promote an action or procedure over the long term.

KEY WORDS: Formulation, Mathematical Model, Computer Oriented, Prediction Calculator.

INTRODUCTION SUSTAINABILITY

In specified circumstances. Sustainability is in more general words, the endurance of systems and processes. Sustainable growth, which covers four interconnected fields, ecology, economics, politics and culture, is the organizing principle for sustainability. Morioka and Carvalho (2016) have explained that the study of sustainable and reliable growth is the science of sustainability.

The sustainability of any structure, product or project is however, measured indirectly in mathematical notes by measuring the output of the indicators or manifest variables on which sustainability depends. In other words, sustainability cannot be specifically calculated, as the Structural Equation Modeling (SEM) definition is a latent dependent variable and is the best approach for calculating it. The main objective of sustainability indicators is to educate policy makers through the development of the statistical model of sustainability tested by Phillips (2010) as part of the process of sustainable governance. In this report, the development of strategic indicators for the sustainability of e-governance projects generally addresses a few indicators, namely performance indicators, efficiency indicators, coverage of functionalities, benefits accrued, availability and impact changes, etc.

STRUCTURAL EQUATION MODELLING (SEM)

Sustainability and dependability in IT computing are the topics explored in this research. Structural Equation Modeling (SEM) has proven to be an effective multivariate statistical analytic method for investigating Structural Relationships and the measurement errors of observable variables, which are Latent dependent variables. The model measures examined by Raykov and Marcoulides might be evaluated using SEM, which could be viewed as a second-generation multivariate technique (2016). The structural equation modelling (SEM) method is a method for examining the link between the seen and latent (unobserved) aspects of a study. It is a combination of confirmatory factor analysis and multiple regression or path analysis. Both endogenous and exogenous variables are employed in this investigation. In this context, endogenous variables are synonymous with dependent variables, while exogenous variables are synonymous with independent variables. The SEM measuring model is depicted in the figure below:

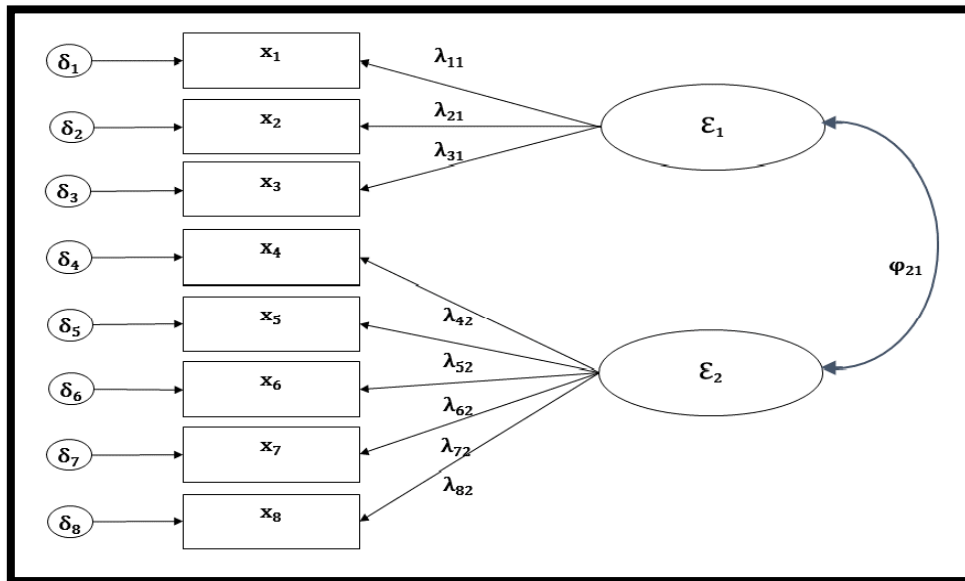

CFA – Measurement Model

CFA is also known within SEM as the measurement model because the step taken to determine how the factors (ϵ_1 and ϵ_2) are measured by the indicators (x_1 to x_8).

SEM's all-encompassing approach to quantifying and verifying substantive theories is one reason for its widespread application to the issues at hand. Structural equation models also have other distinguishing features, such as the fact that they often include latent variables and explicitly account for the measurement error that is common throughout many fields of study. Latent variables are theoretical or hypothetical constructs that play a significant role in the aforementioned challenges; they can also be seen as factors that do not have observed realizations in a sample from a targeted population, such as sustainability and reliability.

Researchers sometimes refer to these types of models by their abbreviation, "LISREL," which stands for "Linear Structural Relations" (a term coined by Jorekog and Sorbom) (2015). An SEM's graphical path diagram and statistical model are typically represented as a matrix of equations. The software required a variety of matrices for the various sets of parameters, such as factor loadings and regression coefficients, and thus we had to extract the matrix representation from the path diagram. As can be seen in Figure 1, the prerequisite study of Structural Equation Modeling's numerous mathematical disciplines includes the following:

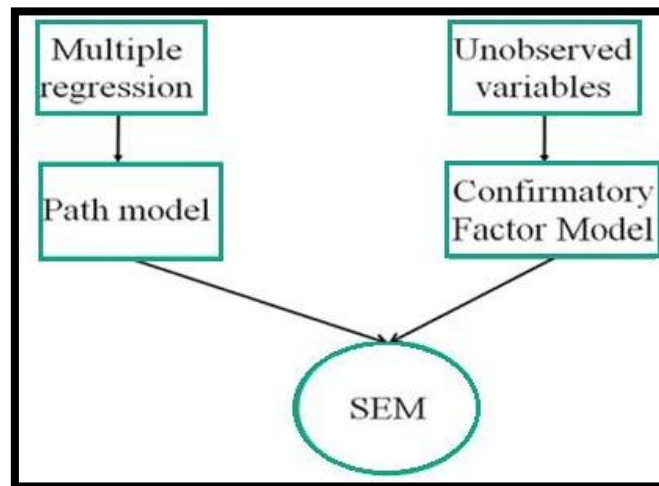

Fig 1 Pre-requisites of Structural Equation Modeling

Numerous regressions are performed to better understand the connection between multiple predictor factors and a single dependent or criterion variable.

Linear regression has been extended into the realm of multiple regressions. As can be seen in the image below, multiple regressions consist of a single dependent variable and two or more independent (exploratory) variables. As can be seen in Figure -2, the variable whose value is to be predicted is called the dependent variable, while the variables whose values are already known are called the independent (exploratory) variables.

As we'll see in the next chapters, it's particularly useful when trying to estimate the value of a variable based on the value of two or more other variables, such as sustainability, which is impossible to measure directly and always depends on a number of characteristics.

In this situation, the sustainability and reliability measures are the dependent variables, also known as the outcome, target, or criteria variable.

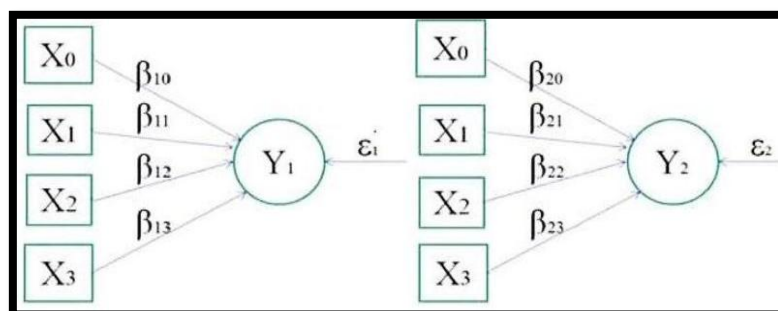

Fig 2 Multiple Regressions with one Dependent Variable

A multivariate linear regression model equation of Y on X independent variables would have the form

$$Y = \alpha + \beta_1 * X_1 + \beta_2 * X_2 + \dots + \beta_p * X_p + E$$

In general multiple regression procedures will estimate a linear equation of the form as shown above:

Note that in this equation, the regression coefficients (or B coefficients) represent the independent contributions of each independent variable to the prediction of the dependent variable. This type of relation is also referred as a partial co-linear regression shown in the Figure 3.

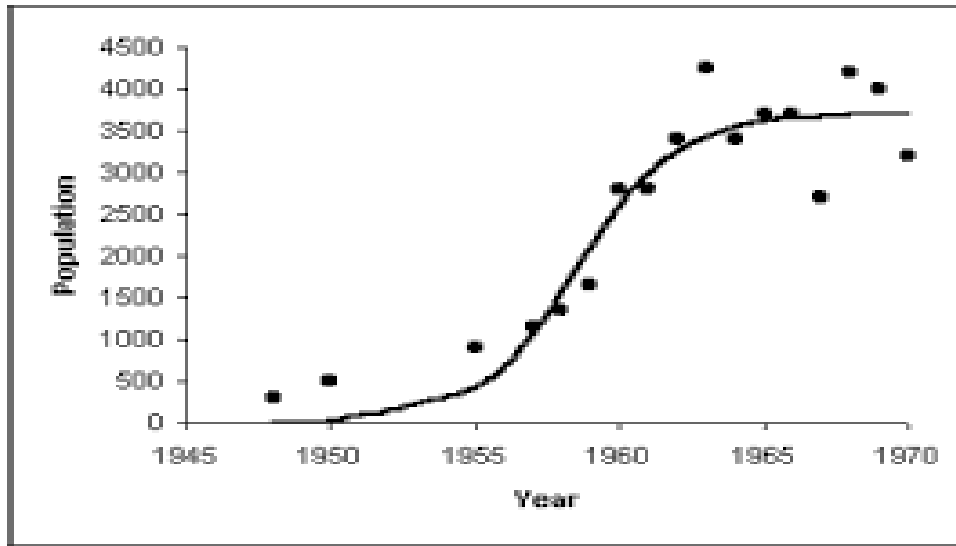

Fig 3 Partial co-linear regression

MATHEMATICAL MODEL OF SUSTAINABILITY

Model of online admission system has been processed using LISREL 9.2 and shown in the Figure 2.5 that how relationship between observable and Latent variables are illustrated and valued and corresponding mathematical equations are considered., where λ is loading of relationship between observed and latent variables, γ is regression coefficients between exogenous (independent) variables and endogenous (dependent) variables, and β is regression coefficient between endogenous variables and other independent variables.

Basic equations of SEM are equation (1), (2) & (3). By substituting equation (1) and equation (2) into equation (3), the model of sustainability equations are obtained as follows:

$$\eta = B * \eta + \Gamma \frac{(X-\delta)}{\Delta x} + \rho \tag{4a}$$

$$\eta = B * \eta + \Gamma * (\Delta x \setminus (X - \delta)) + \rho \tag{4b}$$

From equation (1) to (4b), there are matrices of vectors that can be obtained from Fig 1-3 and Table below by entering the matrices and vectors above, equation (4b) becomes:

$$\begin{bmatrix} \eta_1 \\ \eta_2 \end{bmatrix} = \begin{bmatrix} 0 & 0 \\ 0.975 & 0 \end{bmatrix} \times \begin{bmatrix} 1 \\ 1 \end{bmatrix}_{\text{assumption}} + \begin{bmatrix} 0.450 & -0.71 & 0.008 & 0.646 & 0.221 \\ 0 & 0 & 0 & 0 & 0 \end{bmatrix} * \left[\begin{array}{ccccc} 0.461 & 0 & 0 & 0 & 0 \\ 0.383 & 0 & 0 & 0 & 0 \\ 0.633 & 0 & 0 & 0 & 0 \\ 0 & 0.310 & 0 & 0 & 0 \\ 0 & 0.320 & 0 & 0 & 0 \\ 0 & 0.385 & 0 & 0 & 0 \\ 0 & 0.231 & 0 & 0 & 0 \\ 0 & 0.323 & 0 & 0 & 0 \\ 0 & 0 & 0.01 & 0 & 0 \\ 0 & 0 & -0.037 & 0 & 0 \\ 0 & 0 & -0.021 & 0 & 0 \\ 0 & 0 & -0.009 & 0 & 0 \\ 0 & 0 & 0 & 0.383 & 0 \\ 0 & 0 & 0 & 0.473 & 0 \\ 0 & 0 & 0 & 0.795 & 0 \\ 0 & 0 & 0 & 0.285 & 0 \\ 0 & 0 & 0 & 0 & 0.679 \\ 0 & 0 & 0 & 0 & 0.779 \\ 0 & 0 & 0 & 0 & 0.759 \end{array} \right] \setminus \left[\begin{array}{c} 0.600 \\ 0.478 \\ 0.861 \\ 0.557 \\ 0.463 \\ 0.558 \\ 0.283 \\ 0.483 \\ 0.001 \\ -0.039 \\ -0.022 \\ -0.011 \\ 0.562 \\ 0.691 \\ 1.068 \\ 0.396 \\ 0.903 \\ 1.157 \\ 1.002 \end{array} \right] - \left[\begin{array}{c} 0.195 \\ 0.186 \\ 0.196 \\ 0.388 \\ 0.249 \\ 0.240 \\ 0.188 \\ 0.266 \\ 0.124 \\ 0.147 \\ 0.150 \\ 0.215 \\ 0.251 \\ 0.221 \\ 0.139 \\ 0.236 \\ 0.148 \\ 0.157 \\ 0.126 \end{array} \right] + \begin{bmatrix} 0.001 \\ 0.001 \end{bmatrix} \quad (5)$$

On solving the above equation using MATLAB following results are obtained. However, the values of Factor loadings of X on ξ (Λ_x matrix) have been obtained using LISREL 9.2 (Linear Structural Relations). Also the values of X observed variables (indicators of ξ) have obtained from OUTPUT of LISREL 9.2 in the above matrix, hence following estimates of latent variables obtained:

$$\begin{bmatrix} \eta_1 \\ \eta_2 \end{bmatrix} = \begin{bmatrix} 0.926 \\ 0.904 \end{bmatrix} = \begin{bmatrix} \text{Reliability} \\ \text{Sustainability} \end{bmatrix}$$

The equation can predict the reliability η_1 and sustainability η_2 . Further to obtain observed variables (Indicators) equation (2) need to be rearranged to become equation (6).

$$Y = \begin{bmatrix} \gamma_1 \\ \gamma_2 \\ \gamma_3 \\ \gamma_4 \\ \gamma_5 \\ \gamma_6 \\ \gamma_7 \\ \gamma_8 \\ \gamma_9 \end{bmatrix} = \begin{bmatrix} 0.586 & 0 \\ 0.726 & 0 \\ 0.823 & 0 \\ 0.862 & 0 \\ 0 & 0.763 \\ 0 & 0.579 \\ 0 & 0.673 \\ 0 & 0.684 \\ 0 & 0.545 \end{bmatrix} * \begin{bmatrix} 0.926 \\ 0.904 \end{bmatrix} + \begin{bmatrix} 0.119 \\ 0.110 \\ 0.0996 \\ 0.0829 \\ 0.126 \\ 0.140 \\ 0.160 \\ 0.152 \\ 0.183 \end{bmatrix} \quad (6)$$

$$Y = \begin{bmatrix} \gamma_1 \\ \gamma_2 \\ \gamma_3 \\ \gamma_4 \\ \gamma_5 \\ \gamma_6 \\ \gamma_7 \\ \gamma_8 \\ \gamma_9 \end{bmatrix} = \begin{bmatrix} 0.7417 \\ 0.7823 \\ 0.8618 \\ 0.8812 \\ 0.8707 \\ 0.7051 \\ 0.8168 \\ 0.8196 \\ 0.7149 \end{bmatrix} \quad (7)$$

Following path basic diagram captured after processing of data set of 114 different engineering data samples obtained from the respective colleges:

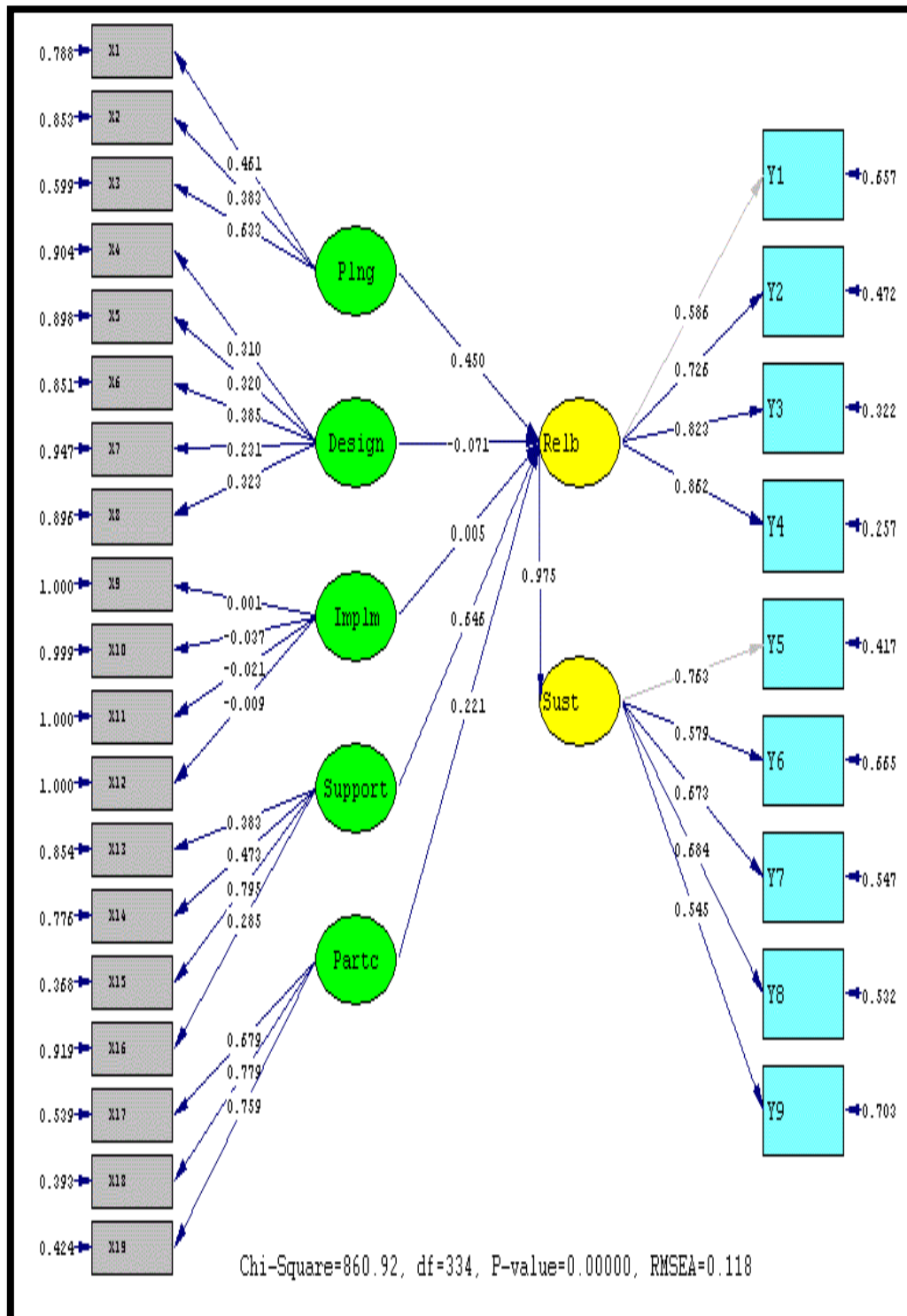

Fig-4 Path Diagram of Basic Model obtained using LISREL 9.2 showing factor loadings and regression weights

Measurement Model of Y manifest variables is given below in Figure 5:

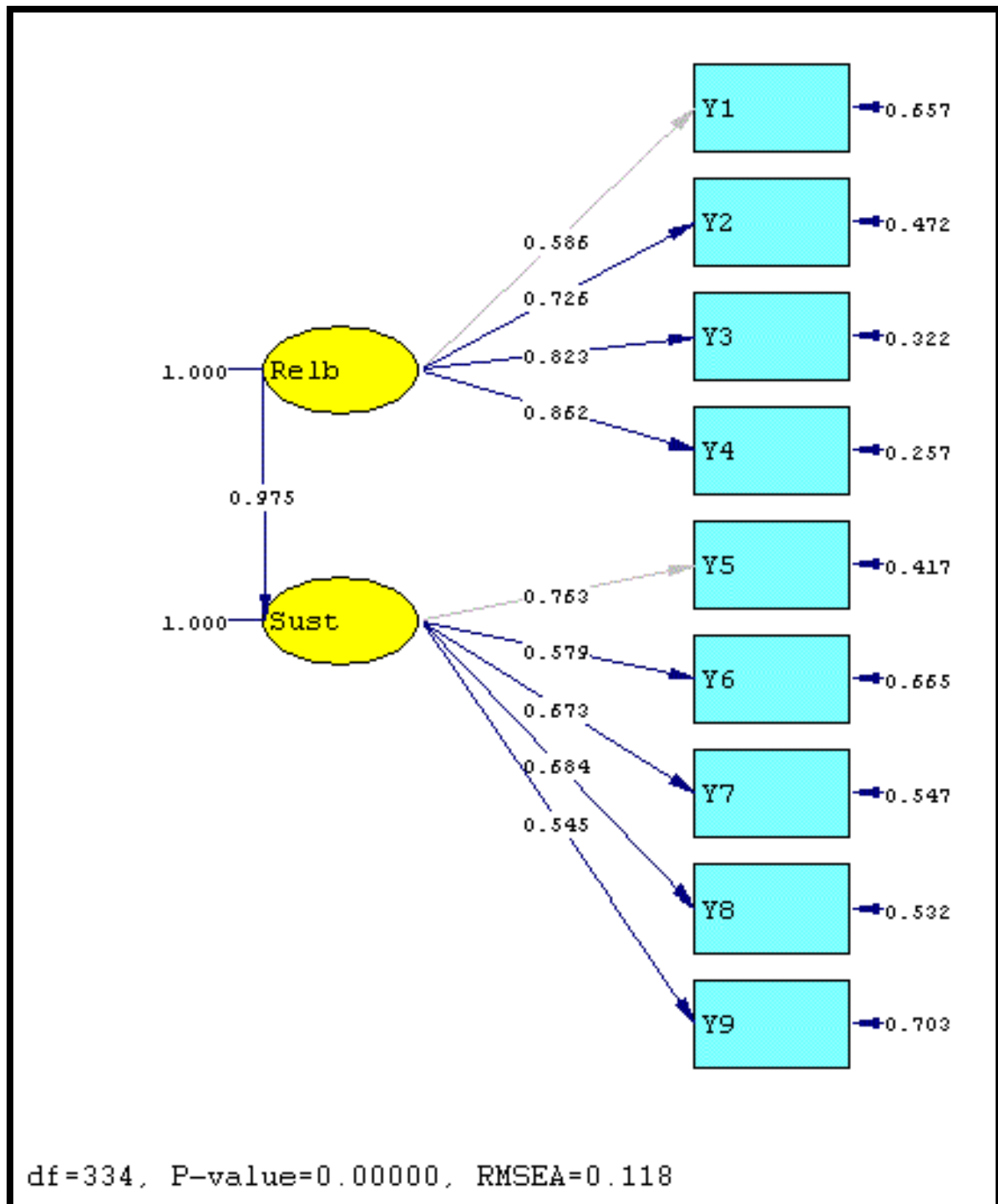

Fig -5 Path Diagram of Standardized estimates of Measurement Model of Dependent Latent variables and their Y observable variables.

Measurement Model of X manifest variables is given below in fig 6:

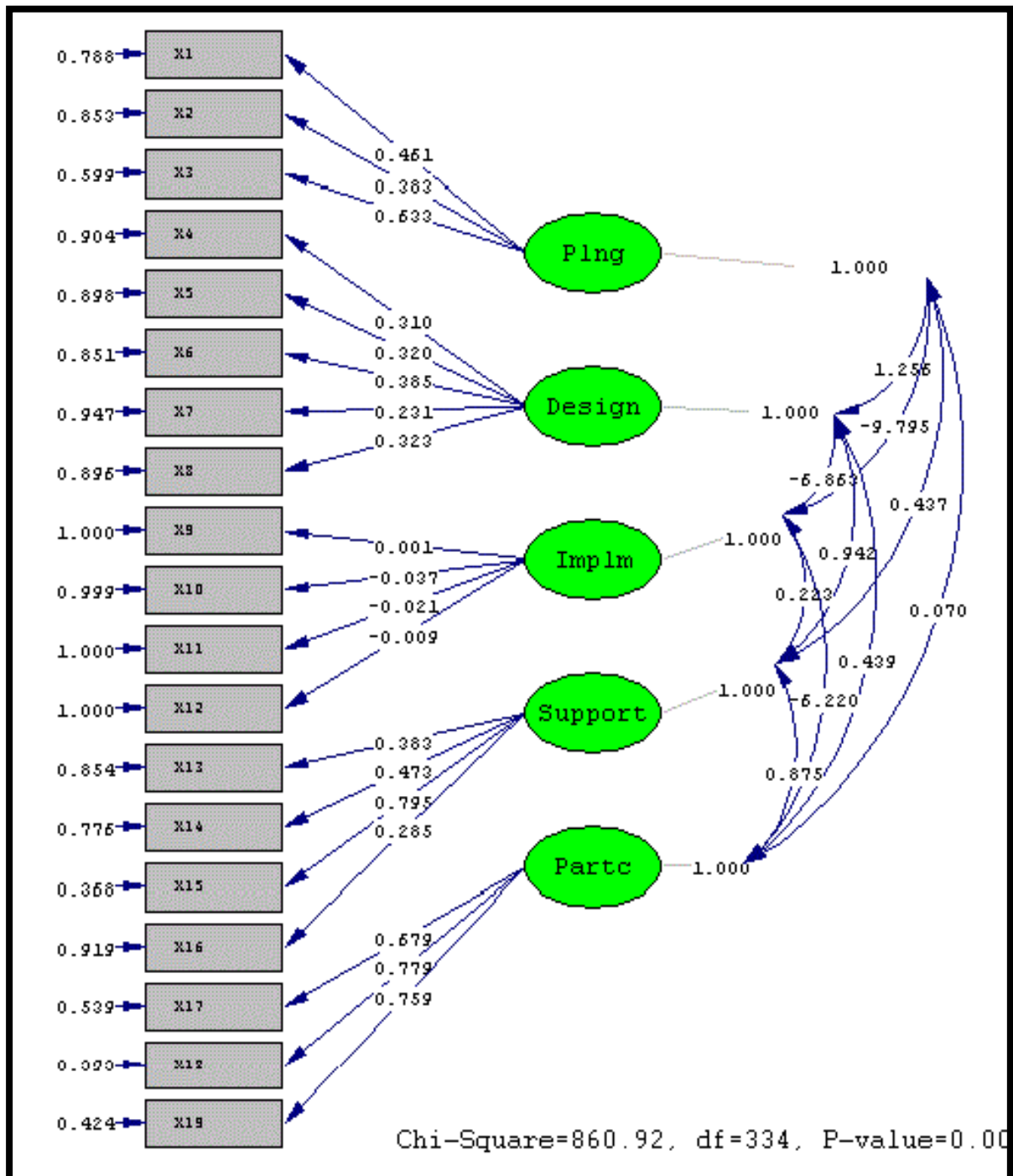

Figure 6. Path Diagram of standardized estimates of measurement model of independent latent variables and their X observable variables

Structural model of latent variables (independent and dependent) is shown in Figure 7

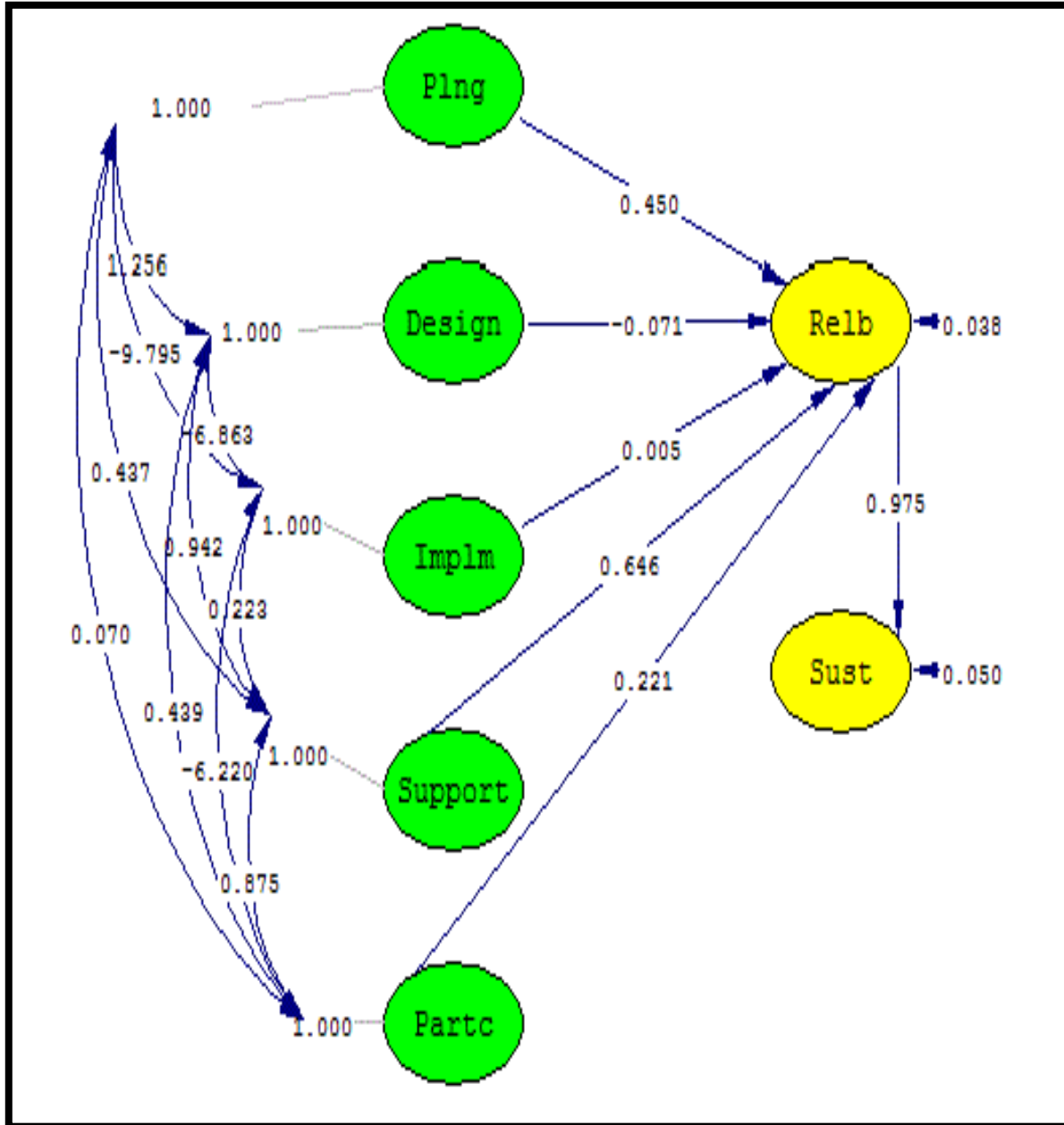

Figure -7. Path diagrams of Standardized estimates of Structural Model of independent and dependent latent variables η & ξ

DISCUSSION AND CONCLUSION

The construction of a mathematical data model and the derivation of the mathematical equations necessary

to compute and estimate sustainability and its range intervals are the outcomes of the study. As a result, recommendations and methods of decision-making concerning the viability and reproducibility of the online off-campus admission system can be decided upon. The tasks that need to be completed before a project plan can be put into action are included in this technique.

As a further conclusion, it can be stated that the primary focus of the discussion in this Chapter is on the computation of the sustainability of the paperless online off campus admission system. This system has been continuously implemented across the state of Haryana by more than 504 institutions since 2006 and has been discovered to be sustainable. The system is quite cost effective, transparent, efficient, and helpful in increasing e-readiness among students and institutions, as well as minimizing the human interference in evaluations and admissions. This is something that can be said from the perspective of both the students and the government. It is necessary to assure sustainability under varying conditions of technology usage, implementation, and capacity building for adequate operations, among other things, in order to replicate the system in other regions and states. This is required in order to accomplish the replication. In light of this, the Structural Equation Modelling technique has been validated through the development of a data model and the derivation of mathematical equations. After that, computing the system's long-term viability required developing and solving co-variance and regression matrices with the help of LISREL and MATLAB respectively. The sustainability index can range anywhere from 3.927 to 0.705, and the standard deviation of the sustainability index in the area under consideration is 0.072198. In addition, advice for decision making, such as the validation of a mathematical model by utilizing a distinct sample of the dataset, the selection of reliable technology, capacity building, and the establishment of help-desks, could be followed to increase the sustainability of the project.

REFERENCES

- Al-Sulaimani, G. J., Kaleemullah, M., Basunbul, I. A., and Rasheeduzzafar (1990), "Influence of corrosion and cracking on bond behavior and strength of reinforced concrete", ACI Struct J. 87 (2), pp 220-231.
- Algina, J., and Moulder, B.C. (2001) "A note on estimating the Jöreskog-Yang model for latent variable interaction using LISREL 8.3" le interaction using LISREL 9,3 Structural Equation Modeling, 8(1), pp. 40 52.
- Almusallam, A., Al-Gahtani, A. S., Aziz, A. R. and Rasheeduzzafar (1996), "Effect of reinforcement corrosion on bond strength, Constr. Build. Mater, 10(2), pp.123 129.

- Anil Monga (2008), “e- government of India” Opportunities and challenges Journal of administration and governance (JOAAG), 3(2), pp.52-61.
- Archibald, R. (2004), “Management of high-tech programs and projects”, New York John Wiley and Sons 1976, pp.191.
- Arhonditsis, G.B., Stow, C.A., Steinberg, L.J., Kenney, M.A., Lathrop, R.C., McBride, S.J. and Reckhow, K.H. (2006), “Exploring ecological patterns with structural equation modeling”, Ecological Modelling, 192, pp. 385-409.
- Baccarini, D., Salm, G. and Peter, E.D. (2004) , “Management of risks in IT projects, Industrial Management and Data Systems, 104(4), pp.286-295.
- Bahadori, M.N. (1978), "Passive Cooling Systems in Iranian Architecture", Scientific American, 238, pp. 144-154.