



---

## ELECTRO-QUASISTATIC HUMAN BODY COMMUNICATION BIOMEDICAL FORMULATION, QUANTIFICATION, AND ENHANCEMENT

Harisha<sup>1</sup> (Research Scholar)

Dr. Yashpal Singh<sup>2</sup> (Research Supervisor)

Department of Electronics & Communication Engineering

<sup>1,2</sup> Sikkim Professional University, Gangtok, (Sikkim)

**Abstract-** Smart products are becoming shorter and have reduced energy demands, as well as becoming less inexpensive. Personally identifiable information plus communication systems have come to embellish our limbs. Phones, pagers, personal computers, and a variety of other equipment fall under this category. However, there seems to be still no means for these devices to communicate knowledge. Several types of devices can be networked to decrease logical I/O repetitions and enable additional advantages and services. Humankind is going through a phase of personal technology, in which computers become seamlessly linked. Regarding connecting to personally identifiable information, transfer files, video, plus telecommunications equipment inside the relatively suburban sizes enabling conversation, three tiers of connecting are required: Local Region Networking (LAN), Wireless Connections (WAN), and Home Lan (HAN). RedTacton is just a network communication standard that leverages the biological body's epidermis as a large and secure network power line. As a result, in this article, we will describe RedTacton's distinctive new functional properties as well as its incredible opportunities as a Humans Space Communication network. The human animal serves as a transmitter for split telecommunication at 10 megabits per second.

**Keywords:** RedTacton, networking technology, Half duplex communication



---

## **Introduction**

Because of the ageing population, there is a growing availability of healthcare screening in hospitals and even at residences. Remote regular monitoring might eliminate the inconvenient nature of wired connections while also saving time and costs [1]. The cordless gadget is typically used as a cardiological detector with seamless connectivity for capturing pulse rate, heartbeat (ECG), electroencephalography (eeg (EEG), and other vital signs. In such a mobile BAN, radio approaches such as the 400-Megahertz, 2.4 GHz range, extra beamwidth (UWB), and anatomical and physiological communications (HBC) spectrum would be used. Several contemporary portable Extracted features are using the 400 Hz & frequency Band radio computer chips (ICs) due to the rapid development of such 2 bandwidths. For illustration, in an astute natural bodily hospital setting, a 433 Frequency band switch keying (FSK) transponder had been used to transfer this same Eeg data to a microcomputer (PC) for monitoring devices, or a 2.4 GHz Wirelessly connectivity ECG with a designed audible alarm function has been used in. A wearable gas pedal had also been built and used the 4 G technology for quick and unobtrusive Ecg signals [2]. Affordable 2.4 GHz receiver ICs are relatively easy to obtain by for wireless Wearable applications. As an on pre - conditioning, on the other hand, is dependent on the operating speed. According to, over 400 MHz, on-body area diffusion contributes upwards of 80% of the receiver sensitivity elements. Because the person's skin is a highly compressed viscoelastic hand, the greater its on transmission distance should become the greater the frequencies. In contrast to that same 2.4 Ghz frequency band of Uplink, that Hba uses the physical species as both a powerful means and runs at wavelengths ranging between thousands of kHz through hundreds of MHz [3]. Mechanism that uses transmission distance is lower at any of these wavelengths than at frequency Band and Ultra - wideband. Its ability to spread and along female organism is now far better than that of breath.



## **Background**

IBM offered interpersonal and inter transmission during the first moment in 1996, and that was afterwards reviewed as published by multiple research organisations throughout the world. Nonetheless, almost all of the described systems had flaws, such as a limited operational capacity (inside the hundreds of micrometers) and then a throughput with just 40 bits per second [4]. 2 Infra, Wireless, and Wireless Radio ID Systems (RFID) are intelligent systems that have been suggested to overcome the "last metre" network problems. However, they had flaws unique to particular, such as a rapid fall in high bandwidth, notably in multi-user environments, resulting in data traffic.

The resolution to each of these issues is RedTacton, which is also an deployment of ubiquity computer networks, as well as two tiers of networking (WAN and LAN), for connecting to personally identifiable information, video, and telecommunication technologies in the context of everyday operations (achieving the last one meter). As a result, the situation of the connection system is referred to as HAN.

## **Selected working system**

RedTacton brings a new perspective in terms of technology. Rather of relying on electromagnetism or photonic particles to transport knowledge [5]. As indicated there in illustration, RedTacton side arm electric potential upon those lower legs as a communication system.

- i) A modest electromagnetic current is induced mostly on surface of the brain by the Random section's receiver.
- ii.) Our RedTacton sensor able to detect changes inside the faint magnetic charge created by that of the broadcaster upon those lower legs.



---

iii.) RedTacton is based on the idea that perhaps the optically characteristics of such a house music crystalline can vary as a small electrical environment changes.

iv.) RedTacton is used to track changes inside of a trip hop crystal's optical response and translates the outcome to an electrical current inside of an optically receiver section.

It is possible to use many transmitters and receivers at the same time [6]. The reason for this is because RedTacton employs a customized CSMA/CD (Carrier Sensor Several Admission with Traffic Monitoring) approach that enables intermediate node to reach the very same media.

### **REDTACTONTRANCEIVER:**

NipponTelegraph as well as Telecommunication Industries invented RedTacton System (NTT).

TACTON - indicating "activity produced by contacting" with RED - a colour associated with compassion in Japanese society. It's a technique that leverages the biological body's natural exterior as a secure, higher bandwidth transmitter. HumanArea Connectivity is a field of research.

i.) Addition to these methods makes use of such a modest electron beam emitted upon that person surface of the cell. It is not to be confused with bluetooth or laser technology.

ii.) When a tissue comes in direct contact with just a RedTacton receiver, a broadcast method as follows. Separation on a physiological level terminates interaction therefore, as a result, dialogue.

iii.) With RedTacton, discussion starts because when person's endpoints are joined in some kind of a variety of categories based upon that participant's normal, bodily actions.

iv.) Each human part, including the arms, fingertips, foot, cheeks, knees, neck, etc chest, can be used to communicate. Clothes or apparel are also used by Blue Tacton.

## Features

The 3 major essential features of RedTacton Nanotechnology are: Reaching, standing, standing, leaping, grabbing, and many other people 's actions can be employed as signals for releasing or concealing the technology, commencing or terminating it, or getting data.

ii.) Broadband & Engaging: Connectivity doesn't somehow degrade even when bidirectional processes and multiple users are using the network at the same time. At quite a top range of gigabits per second, simultaneous interactive communication can occur. Since the series circuit seems to be on the lower legs, red tacton data transmission somehow doesn't degrade in packed regions where multiple students can speak at about the same time.

iii.) Any medium: Aside from the human body, a variety of conductors and dielectric constants can really be employed as transmitting data [7]. Combining conductive with dielectric material also was possible.

## Previous Workon Electric Field Sensing

Professor Michael Hawley's Private Information Management Project plus Doctor David Gershenfeld's Chemistry & Multimedia Department, both at the Hi - media Center, met to build the Humans Local Network (HAN). Lecturer Hawley's monitoring visits a sense of connection muscle communications transmitters, while Doctor Gershenfeld's department was working on up or down using electrostatic force sense.

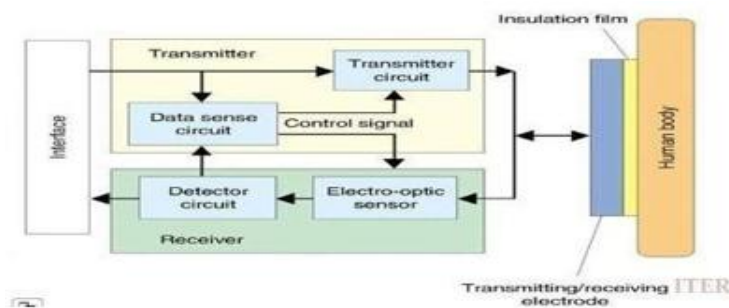

**Fig 1: Block diagram of RedTacton Transceiver** (Source: Modak *et al.* 2020)

The broadcaster is made up of a signal generator that emits electric potential towards to brain and an information sensor loop that detects either transmitter / receiver material or generates control commands distinction between two modalities to repeated loading communications. To prevent packet losses, an end up receiving quarter connection strategy is implemented, which broadcasts after only ensuring there's no content for send [8]. A hard electromagnetic field which surrounding your female condition is exploited by RedTacton.

### Block diagram

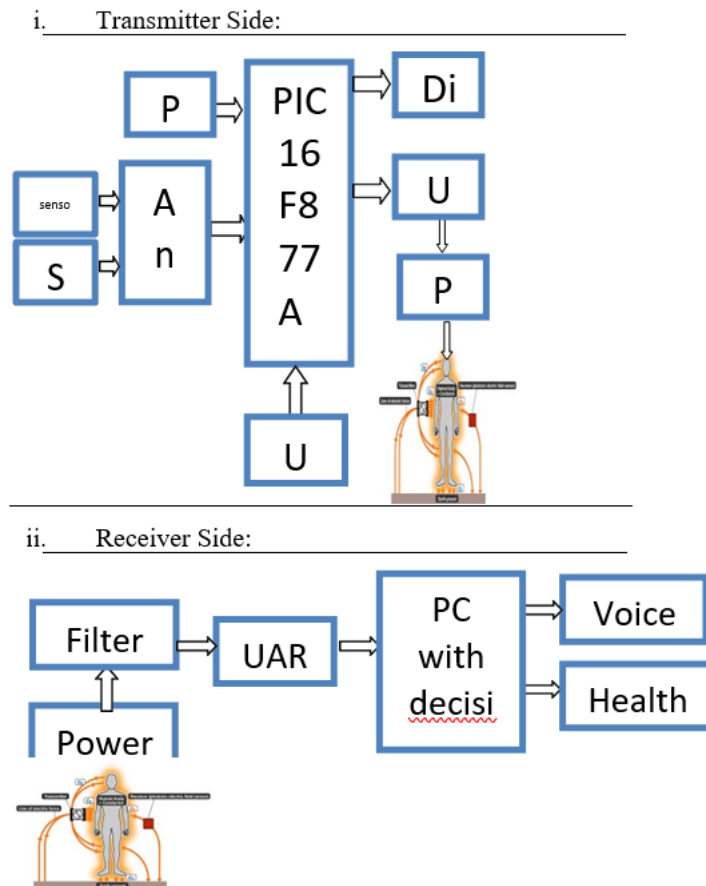

Fig 2: Block diagram of slide view

(Source: Salam 2020)



---

## **Introduction in LABVIEW**

The visual basic programming paradigm is used in LabVIEW. O m is the name for this sort of programming (for graphical code). International Electronics' programme is usually employed in commerce for a wide variety of uses [9]. The mechanization of data collection is one of these proved. Because many studies are conducted beneath controlled environments, altering these parameters is an important aspect of the research. Several device variables can be altered electronically rather than individually if using LabVIEW. This is indeed useful whenever a range of measures over a variety of parameters are required. For example, you will indeed be requested to utilise LabVIEW to obtain voltage readings for a device later this semester [10]. There were about four observations per voltage level variation, and so these data build up to a huge set of observations over a given set of input power supply (and time). Which one if you could programme a supercomputer to modify and monitor every one of the various metrics for you? Experimentation become ever more productive or take lesser time because of this. By instead bothering over how this is set up and making knobs & settings on the all the apparatus, the researchers can take data they're obtaining [11]. These fundamentals of LabVIEW computing will just be explained throughout this lab, and also the pupils) will just be entrusted to figure out is how to change the coding to fulfill the demand of research.

## **Conclusion**

This type of interaction to which the components are attached is the first point to remember about LabVIEW scripting. The gadgets there in lab use GPIB, or Special Purpose Interconnect Bus, which has evolved into the IEEE 488.2 standards. An RS-232 connector (serial port) is also available; however, it is ineffective for the hardware at hands. Its GPIB connectors are similar to the SCSI connection seen on computers. This is owing to the devices' capacity to join in a "daisy chain" fashion. There are many markings here on front of both the equipment just on bench top that indicate 'IEEE 488' or 'GPIB Adapter.' Such wires return toward the controller, which is placed within the machine. This really is the interface via which the computer communicates



---

with the various types of kit. The method for determining whether devices need addressing is handled by the software. Whatever be shown toward the bridge can indeed be accessed or modified in LabVIEW simply modifying the GPIB location within programme.

## References

- [1] Modak, N., Nath, M., Chatterjee, B., Maity, S. and Sen, S., 2020. Bio-Physical Modeling of Galvanic Human Body Communication in Electro-Quasistatic Regime. *bioRxiv*.
- [2] Sriram, S., Avlani, S., Ward, M.P. and Sen, S., 2020. Electro-Quasistatic Animal Body Communication for Chronic Untethered Rodent Biopotential Recording. *arXiv preprint arXiv:2005.05370*.
- [3] Polachan, K., Chatterjee, B., Weigand, S. and Sen, S., 2021. Human Body–Electrode Interfaces for Wide-Frequency Sensing and Communication: A Review. *Nanomaterials*, 11(8), p.2152.
- [4] Salam, A., 2020. Internet of things for sustainable human health. In *Internet of Things for Sustainable Community Development* (pp. 217-242). Springer, Cham.
- [5] Chatterjee, B., Cao, N., Raychowdhury, A. and Sen, S., 2019. Context-aware intelligence in resource-constrained IoT nodes: Opportunities and challenges. *IEEE Design & Test*, 36(2), pp.7-40.
- [6] Raben, H., Kämmerer, P.W., Bader, R. and van Rienen, U., 2019. Establishment of a numerical model to design an electro-stimulating system for a porcine mandibular critical size defect. *Applied Sciences*, 9(10), p.2160.
- [7] Budde, K., Zimmermann, J., Neuhaus, E., Schröder, M., Uhrmacher, A.M. and van Rienen, U., 2019, July. Requirements for Documenting Electrical Cell Stimulation Experiments for Replicability and Numerical Modeling\*. In *2019 41st Annual International Conference of the IEEE Engineering in Medicine and Biology Society (EMBC)* (pp. 1082-1088). IEEE.
-





---

[8] Wenger, C., Miranda, P.C., Salvador, R., Thielscher, A., Bomzon, Z., Giladi, M., Mrugala, M.M. and Korshoej, A.R., 2018. A review on tumor-treating fields (TTFields): clinical implications inferred from computational modeling. *IEEE Reviews in Biomedical Engineering*, 11, pp.195-207.

[9] Aazhang, B., Abe, E., Abedinpour, K., Abeyratne, U.R., Abiri, A., Abohtyra, R., Abry, P., Abubakar, A., Acharyya, A., Acioli-Santos, B. and Adalsteinsson, E., 2019. 2019 Index IEEE Transactions on Biomedical Engineering Vol. 66. *IEEE Transactions on Biomedical Engineering*, 66(12).

[10] van Rienen, U., Zimmermann, U., Raben, H. and Kämmerer, P.W., 2018. Preliminary Numerical Study on Electrical Stimulation at Alloplastic Reconstruction Plates of the Mandible. In *Scientific Computing in Electrical Engineering* (pp. 3-11). Springer, Cham.

[11] Zimmermann, J., Distler, T., Boccaccini, A.R. and van Rienen, U., 2020. Numerical Simulations as Means for Tailoring Electrically Conductive Hydrogels towards Cartilage Tissue Engineering by Electrical Stimulation. *Molecules*, 25(20), p.4750.